

# Transistor

## NPN Transistors BC546~BC548

### ■ Features

- High Voltage
- Complement to BC556,BC557,BC558

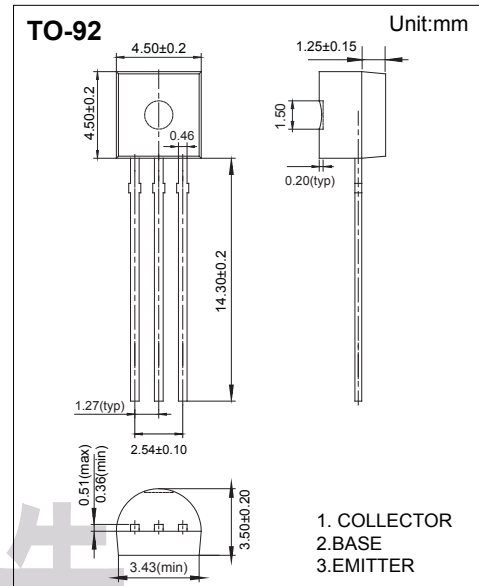

### ■ Absolute Maximum Ratings $T_a = 25^\circ\text{C}$

Parameter	Symbol	Rating	Unit
Collector - Base Voltage	BC546	80	V
	BC547	50	
	BC548	30	
Collector - Emitter Voltage	BC546	65	
	BC547	45	
	BC548	30	
Emitter - Base Voltage	BC546	6	
	BC547	6	
	BC548	5	
Collector Current - Continuous	$I_c$	0.1	A
Collector Power Dissipation	$P_c$	625	mW
Thermal Resistance from Junction to Ambient	$R_{\theta JA}$	200	$^\circ\text{C/W}$
Junction Temperature	$T_J$	150	$^\circ\text{C}$
Storage Temperature	$T_{stg}$	-55 to 150	

# Transistor

## NPN Transistors BC546~BC548

### ■ Electrical Characteristics Ta = 25°C

Parameter	Symbol	Testconditons	Min	Typ	Max	Unit
Collecto- base breakdown voltage	BC546	$I_c = 100 \mu A, I_E = 0$	80			V
	BC547		50			
	BC548		30			
Collector- emitter breakdown voltage	BC546	$I_c = 1 mA, I_B = 0$	65			V
	BC547		45			
	BC548		30			
Emitter - base breakdown voltage	BC546	$I_E = 10 \mu A, I_c = 0$	6			V
	BC547		6			
	BC548		5			
Collector cut-off current	BC546	$V_{CB} = 70 V, I_E = 0$			0.1	$\mu A$
	BC547	$V_{CB} = 50 V, I_E = 0$				
	BC548	$V_{CB} = 30 V, I_E = 0$				
Collector cut-off current	BC546	$V_{CE} = 60 V, I_B = 0$			0.1	$\mu A$
	BC547	$V_{CE} = 45 V, I_B = 0$				
	BC548	$V_{CE} = 30 V, I_B = 0$				
Emitter cut-off current	$I_{EBO}$	$V_{EB} = 5 V, I_c = 0$			0.1	$\mu A$
Collector-emitter saturation voltage	$V_{CE(sat)}$	$I_c = 100 mA, I_B = 5 mA$			0.3	V
Base - emitter saturation voltage	$V_{BE(sat)}$	$I_c = 100 mA, I_B = 5 mA$			1.1	
Base-emitter voltage	$V_{BE}$	$V_{CE} = 5 V, I_c = 2 mA$	0.58		0.7	
		$V_{CE} = 5 V, I_c = 10 mA$			0.75	
DC current gain	$h_{FE}$	$V_{CE} = 5 V, I_c = 2 mA$	110		800	
Collector output capacitance	$C_{ob}$	$V_{CB} = 10 V, I_E = 0, f = 1 MHz$			4.5	pF
Transition frequency	$f_T$	$V_{CE} = 5 V, I_c = 10 mA, f = 100 MHz$	150			MHz

### ■ Classification of hFE

Rank	A	B	C
Range	110-220	200-450	420-800